



**Wilson, D. (2012) Real Geometry and Connectedness via
Triangular Description: CAD Example Bank. [Dataset]**

Link to official URL (if available):

Opus: University of Bath Online Publication Store

<http://opus.bath.ac.uk/>

This version is made available in accordance with publisher policies.
Please cite only the published version using the reference above.

See <http://opus.bath.ac.uk/> for usage policies.

Please scroll down to view the document.

Polynomial System Example Bank

Version 4.0 - 1/4/13

David John Wilson
PhD Candidate, University of Bath

Current draft: April 8, 2013

Contents

1	Introduction	2
2	Examples from CMXY09	3
3	Branch Cut Examples	8
4	Motion Planning Examples	10
5	Examples from Buchberger–Hong [BH91]	11
6	Other Examples	15
7	Joukowski Transformation	19
8	TTICAD Examples	20
A	Figures	26

1 Introduction

This file contains a collection of examples for use in evaluating algorithms related to cylindrical algebraic decomposition.

This file is stored permanently at <http://www.cs.bath.ac.uk/~djw42/triangular/examplebank.pdf>. This file is intended as a reference file for the MAPLE file (stored at <http://www.cs.bath.ac.uk/~djw42/triangular/examplebank.txt>) and the QEPCAD file (stored at <http://www.cs.bath.ac.uk/~djw42/triangular/QEPCADexamplebank.txt>). Please check this URL to ensure you have the most up to date copies of the files.

Each example is given as a Tarski formula or list of polynomials followed by a list of free variables, a list of quantified variables, the suggested variable order given from the source (if any), the minimal number of cells achieved in a full CAD (with details of how to reproduce), notes on the problem, and the source.

1.1 Minimality

At the moment, the minimal cells fields are all conducted through MAPLE. In the future they will include QEPCAD results. They respect the requirement that quantified variables must come before (in MAPLE notation) the free variables.

1.2 Paper-specific Details

The following examples have been used in the stated papers:

- “Speeding up Cylindrical Algebraic Decomposition by Gröbner Bases” by D. J. Wilson, R. J. Bradford and J. H. Davenport:
 - From Section 2: 2, 4, 6–8, 13–14;
 - From Section 5: 1–10;
 - From Section 6: 12–13.

Note that Example 5.7 and Example 2.15 are actually reformulations of the same Solotareff problem. An explanation for this is given at <http://www.cs.bath.ac.uk/~djw42/triangular/solotareff3.pdf>.

This repository is obviously a work in progress and is intended to be an open resource for research into cylindrical algebraic decomposition and quantifier elimination. If you have a suggestion for a suitable example to include or an alteration to the structure and implementation then please contact me on D.J.Wilson@bath.ac.uk.

2 Examples from [CMXY09]

2.1 Parametric Parabola

$$(\exists x) [ax^2 + bx + c = 0] \quad (1)$$

Free Variables: a, b, c .

Quantified Variables: x .

Suggested variable order: $x > c > b > a$.

Best achieved number of cells: 27 - with MAPLE and variable ordering $[x, c, b, a]$ (that is, $x > c > b > a$).

Notes: Without quantifying on x the problem can become rather simple; it is possible to construct CAD's containing only 3 cells.

Source: [CMXY09]

2.2 Whitney Umbrella

$$(\exists u)(\exists v) [x - uv = 0 \wedge y - v = 0 \wedge z - u^2 = 0] \quad (2)$$

Free Variables: x, y, z .

Quantified Variables: u, v .

Suggested variable order: $v > u > z > y > x$.

Best achieved number of cells: 895 - with MAPLE and variable ordering $[v, u, z, y, x]$ (that is $v > u > z > y > x$).

Notes: Without quantification it is possible to get a CAD containing 27 cells (in MAPLE with variable order $[x, y, z, u, v]$).

Source: [CMXY09]

2.3 Quartic

$$(\forall x) [x^4 + px^2 + qx + r \geq 0] \quad (3)$$

Free Variables: p, q, r .

Quantified Variables: x .

Suggested variable order: $x > p > q > r$

Best achieved number of cells: 177 - with MAPLE and variable ordering $[x, r, p, q]$ (that is $x > p > q > r$).

Notes:

Source: [Laz88]

2.4 Sphere and Catastrophe

$$z^2 + y^2 + x^2 - 1 = 0 \quad z^3 + xz + y = 0 \quad (4)$$

Free Variables: x, y, z .

Quantified Variables:

Suggested variable order: $x > y > z$

Best achieved number of cells: 149 - with MAPLE and variable ordering $[y, z, x]$ (that is $y > z > x$).

Notes: Full CAD

Source: [McC88]

2.5 Arnon-84

$$y^4 - 2y^3 + y^2 - 3x^2y + 2x^4 = 0 \quad (5)$$

Free Variables: x, y .

Quantified Variables:

Suggested variable order: $y > x$.

Best achieved number of cells: 37 - with MAPLE and variable ordering $[x, y]$ (that is $x > y$).

Notes:

Source: [CMA82]

2.6 Arnon-84-2

$$144y^2 + 96x^2y + 9x^4 + 105x^2 + 70x - 98 = 0 \quad (6)$$

$$xy^2 + 6xy + x^3 + 9x = 0 \quad (7)$$

Free Variables: x, y .

Quantified Variables:

Suggested variable order: $y > x$.

Best achieved number of cells: 41 - with MAPLE and variable ordering $[y, x]$ (that is $y > x$).

Notes:

Source: [CMA82]

2.7 A Real Implicitization Problem

$$(\exists u)(\exists v) [x - uv = 0 \wedge y - uv^2 = 0 \wedge z - u^2 = 0] \quad (8)$$

Free Variables: x, y, z .

Quantified Variables: u, v .

Suggested variable order: $v > u > z > y > x$.

Best achieved number of cells: 895 - with MAPLE and variable ordering $[v, u, z, y, x]$ (that is $v > u > z > y > x$).

Notes:

Source: [DSS04]

2.8 Ball and Circular Cylinder

$$(\exists z)(\exists x)(\exists y) [[x^2 + y^2 + z^2 - 1 < 0] \wedge [x^2 + (y + z - 2)^2 - 1 < 0]] \quad (9)$$

Free Variables:

Quantified Variables: x, y, z .

Suggested variable order: $z > y > x$

Best achieved number of cells: 193 - with MAPLE and variable ordering $[x, y, z]$ (that is $x > y > z$).

Notes: Decides whether the intersection of the open ball with radius 1 centered at the origin and the open circular cylinder with radius 1 and axis the line $x = 0, y + z = 2$ is nonempty.

Source: [McC88]

2.9 Termination of Term Rewrite System

$$(\exists r)(\forall x)(\forall y) \left[[x - r > 0] \wedge [y - r > 0] \right. \\ \left. \longrightarrow [x^2(1 + 2y)^2 - y^2(1 + 2x^2) > 0] \right] \quad (10)$$

Free Variables:

Quantified Variables: r, x, y .

Suggested variable order: $y > x > r$.

Best achieved number of cells: 207 (MAPLE with suggested ordering).

Notes: Decides whether we should orient the equation $(xy)^{-1} = y^{-1}x^{-1}$ into $(xy)^{-1} \rightarrow y^{-1}x^{-1}$ in order to get a terminating rewrite system for group theory. It uses a polynomial interpretation: $xy \Rightarrow x + 2xy$, $x^{-1} \Rightarrow x^2$, and $1 \Rightarrow 2$.

Source: [CH91]

2.10 Collins and Johnson

$$(\exists r) \left[[3a^2r + 3b^2 - 2ar - a^2 - b^2 < 0] \right. \\ \wedge [3a^2r + 3b^2r - 4ar + r - 2a^2 - 2b^2 + 2a > 0] \\ \left. \wedge \left[a - \frac{1}{2} \geq 0 \right] \wedge [b > 0] \wedge [r > 0] \wedge [r - 1 < 0] \right] \quad (11)$$

Free Variables: a, b .

Quantified Variables: r .

Suggested variable order: $r > a > b$.

Best achieved number of cells: 3673 (MAPLE with suggested ordering).

Notes: Necessary and sufficient conditions on the complex conjugate roots $a \pm bi$ so that there exists a cubic polynomial with a single real root r in $(0, 1)$ yet more than one variation is obtained.

Source: [CH91]

2.11 Range of Lower Bounds

$$(\forall x)(\forall a)(\forall b)(\forall c)(\exists z) \left[[(a > 0) \wedge (az^2 + bz + c \neq 0)] \right. \\ \left. \longrightarrow [y < ax^2 + bx + c] \right] \quad (12)$$

Free Variables: y .

Quantified Variables: a, b, c, x, z .

Suggested variable order: $z > c > b > a > x > y$

Best achieved number of cells: 333 ((MAPLE with suggested ordering).

Notes: With a partial CAD QEPCAD only produces 3 cells.

Source: [DSS04]

2.12 X-axis Ellipse Problem

$ab \neq 0 \wedge$

$$(\forall x)(\forall y) \left[[b^2(x-c)^2 + a^2y^2 - a^2b^2 = 0] \longrightarrow [x^2 + y^2 - 1 \leq 0] \right] \quad (13)$$

Free Variables: a, b, c .

Quantified Variables: x, y .

Suggested variable order: $y > x > b > c > a$.

Best achieved number of cells:

Notes: Partial CAD in QEPCAD produces 1443 cells.

Source: [DSS04]

2.13 Davenport and Heintz

$$(\exists c)(\forall b)(\forall a) \left[[a-d=0 \wedge b-c=0] \vee [a-c=0 \wedge b-1=0] \right. \\ \left. \longrightarrow a^2 - b = 0 \right] \quad (14)$$

Free Variables: d .

Quantified Variables: a, b, c .

Suggested variable order: $a > b > c > d$

Best achieved number of cells: 4943 (MAPLE with suggested ordering).

Notes: A special case of a more general formula. A partial CAD in QEPCAD produces only 7 cells.

Source: [DH88],[CH91]

2.14 Hong-90

$$(\exists a)(\exists b) \left[[r+s+t=0] \wedge [rs+st+tr-a=0] \wedge [rst-b=0] \right] \quad (15)$$

Free Variables: r, s, t .

Quantified Variables: a, b .

Suggested variable order: $b > a > t > s > r$.

Best achieved number of cells:

Notes: A partial CAD in QEPCAD produces only 3 cells.

Source: [Hon90]

2.15 Solotareff-3

$$(\exists u)(\exists v) \left[[r > 0] \wedge [r-1 > 0] \wedge [u+1 > 0] \wedge [u-v < 0] \wedge \right. \\ [v-1 < 0] \wedge [3u^2 + 2ru - a = 0] \wedge [3v^2 + 2rv - a = 0] \wedge \\ \left. [u^3 + ru^2 - au + a - r - 1 = 0] \wedge [v^3 + rv^2 - av - 2b - a + r + 1 = 0] \right] \quad (16)$$

Free Variables: a, b, r, u, v .

Quantified Variables:

Suggested variable order: $v > u > b > r > a$.

Best achieved number of cells: 66675 (MAPLE with suggested ordering).

Notes: A reformulation of Solotareff's problem using the outline in [Ach56].

A partial CAD in QEPCAD produces 771 cells.

Source: [CMXY09], [Ach56]

2.16 Collision Problem

$$\begin{aligned} (\exists t)(\exists x)(\exists y) & \left[\left[\frac{17}{16}t - 6 \geq 0 \right] \wedge \left[\frac{17}{16}t - 10 \leq 0 \right] \right. \\ & \wedge \left[x - \frac{17}{16}t + 1 \geq 0 \right] \wedge \left[x - \frac{17}{16}t - 1 \leq 0 \right] \\ & \wedge \left[y - \frac{17}{16}t + 9 \geq 0 \right] \wedge \left[y - \frac{17}{16}t + 7 \leq 0 \right] \\ & \left. \wedge [(x-t)^2 + y^2 - 1 \leq 0] \right] \quad (17) \end{aligned}$$

Free Variables:

Quantified Variables: t, x, y .

Suggested variable order: $t > x > y$.

Best achieved number of cells:

Notes: Collision of two semi-algebraic objects: a circle with radius 1, initially centered at $(0, 0)$ and moving with velocity $v_x = 1$ and $v_y = 0$; a square with side-length 2, initially centered at $(0, -8)$ and moving with velocity $v_x = \frac{17}{16}$ and $v_y = \frac{17}{16}$.

Source: [CH91]

2.17 McCallum Trivariate Random Polynomial

$$(y-1)z^4 + xz^3 + x(1-y)z^2 + (y-x-1)z + y \quad (18)$$

Free Variables: x, y, z .

Quantified Variables:

Suggested variable order: $z > y > x$.

Best achieved number of cells:

Notes:

Source: [McC88]

2.18 Ellipse Problem

$$\begin{aligned} [ab \neq 0] \wedge (\forall x)(\forall y) & \left[[b^2(x-c)^2 + a^2(y-d)^2 - a^2b^2 = 0] \right. \\ & \left. \longrightarrow [x^2 + y^2 - 1 \leq 0] \right] \quad (19) \end{aligned}$$

Free Variables: a, b, c, d .

Quantified Variables: x, y .

Suggested variable order: $y > x > d > c > b > a$.

Best achieved number of cells:

Notes:

Source: [CMXY09]

3 Branch Cut Examples

3.1 Kahan A

$$\begin{aligned}
& [[[8y^3x + 8yx^3 + 20y^3 + 84yx^2 + 288yx + 324y = 0] \wedge \\
& [-225x^2 - 324x + 63y^2 - 4x^4 - 52x^3 + 12y^2x + 4y^4 < 0]] \vee [[2y = 0] \wedge [2x + 9 < 0]] \vee \\
& [[8y = 0] \wedge [8x^2 + 56x + 8y^2 + 96 < 0]] \vee [[y = 0] \wedge [x^2 + 7x + y^2 + 12 < 0]] \vee \\
& \quad [[8y^3x + 8yx^3 + 20y^3 + 84yx^2 + 288yx + 324y = 0] \wedge \\
& \quad [-4x^4 - 52x^3 - 252x^2 + 12y^2x - 540x + 36y^2 + 4y^4 - 432 \leq 0] \wedge \\
& \quad [4x^4 + 52x^3 + 225x^2 - 12y^2x + 324x - 63y^2 - 4y^4 < 0]] \vee \\
& \quad [[2y = 0] \wedge [-2x - 6 < 0] \wedge [2x \leq 0]] \vee [[8y = 0] \wedge \\
& \quad [-8x^2 - 56x - 8y^2 - 96 < 0] \wedge [2x^2 + 8x + 2y^2 \leq 0]]] \quad (20)
\end{aligned}$$

Free Variables: y, x

Quantified Variables:

Suggested Variable ordering: $y > x$

Best achieved number of cells:

Notes:

Source:

3.2 Kahan B

$$\begin{aligned}
& [[[8y^3x + 8yx^3 + 20y^3 + 84yx^2 + 288yx + 324y = 0] \wedge \\
& [-225x^2 - 324x + 63y^2 - 4x^4 - 52x^3 + 12y^2x + 4y^4 < 0]] \vee [[2y = 0] \wedge [2x + 9 < 0]] \vee \\
& [[8y = 0] \wedge [8x^2 + 56x + 8y^2 + 96 < 0]] \vee [[y = 0] \wedge [x^2 + 7x + y^2 + 12 < 0]] \vee \\
& \quad [[8y^3x + 8yx^3 + 20y^3 + 84yx^2 + 288yx + 324y = 0] \wedge \\
& \quad [-4x^4 - 52x^3 - 252x^2 + 12y^2x - 540x + 36y^2 + 4y^4 - 432 \leq 0] \wedge \\
& \quad [4x^4 + 52x^3 + 225x^2 - 12y^2x + 324x - 63y^2 - 4y^4 < 0]] \vee \\
& \quad [[2y = 0] \wedge [-2x - 6 < 0] \wedge [2x \leq 0]] \vee [[8y = 0] \wedge \\
& \quad [-8x^2 - 56x - 8y^2 - 96 < 0] \wedge [2x^2 + 8x + 2y^2 \leq 0]]] \quad (21)
\end{aligned}$$

Free Variables: y, x

Quantified Variables:

Suggested Variable ordering: $x > y$

Best achieved number of cells:

Notes:

Source:

3.3 ArcSin A

$$\begin{aligned}
& [[[-2xy = 0] \wedge [y^2 - x^2 + 1 < 0]] \vee [[16y^3x - 16yx^3 + 8yx = 0] \wedge \\
& [1 - 4x^2 + 4y^2 + 4x^4 - 24x^2y^2 + 4y^4 \leq 0]] \vee [[y = 0] \wedge [1 - x \leq 0]] \\
& \quad \vee [[y = 0] \wedge [x + 1 \leq 0]]] \quad (22)
\end{aligned}$$

Free Variables: y, x
 Quantified Variables:
 Suggested Variable ordering: $y > x$
 Best achieved number of cells:
 Notes:
 Source:

3.4 ArcSin B

$$\begin{aligned}
 & [[[-2xy = 0] \wedge [y^2 - x^2 + 1 < 0]] \vee [[16y^3x - 16yx^3 + 8yx = 0] \wedge \\
 & [1 - 4x^2 + 4y^2 + 4x^4 - 24x^2y^2 + 4y^4 \leq 0]] \vee [[y = 0] \wedge [1 - x \leq 0]] \\
 & \vee [[y = 0] \wedge [x + 1 \leq 0]]] \quad (23)
 \end{aligned}$$

Free Variables: y, x
 Quantified Variables:
 Suggested Variable ordering: $x > y$
 Best achieved number of cells:
 Notes:
 Source:

4 Motion Planning Examples

4.1 Piano Mover's Problem (Davenport)

$$\begin{aligned} & \left[[(x - x')^2 + (y - y')^2 - 9 = 0] \wedge \right. \\ & \quad \left. [[yy' \geq 0] \vee [x(y - y')^2 + y(x' - x)(y - y') \geq 0]] \wedge \right. \\ & \quad \left. [[(y - 1)(y' - 1) \geq 0] \vee [(x + 1)(y - y')^2 + (y - 1)(x' - x)(y - y') \geq 0]] \wedge \right. \\ & \quad \left. [[xx' \geq 0] \vee [y(x - x')^2 + x(y' - y)(x - x') \geq 0]] \wedge \right. \\ & \quad \left. [[(x + 1)(x' + 1) \geq 0] \vee [(y - 1)(x - x')^2 + (x + 1)(y' - y)(x - x') \geq 0]] \right]. \end{aligned} \tag{24}$$

Free Variables: x, x', y, y' .

Quantified Variables:

Suggested Variable Order: $x > y > a > b$

Best achieved number of cells:

Notes:

Source: [Dav86]

5 Examples from Buchberger–Hong [BH91]

All the following examples have an 'A' and 'B' form which correspond to alternative variable orderings of the same problem.

5.1 Intersection A

$$(\exists z) \left[x^2 - \frac{1}{2}y^2 - \frac{1}{2}z^2 = 0 \right] \wedge [xz + zy - 2x = 0] \wedge [z^2 - y = 0]. \quad (25)$$

Free Variables: x, y .

Quantified Variables: z .

Suggested variable order: $z > y > x$

Minimal achieved number of cells: 2795 – with MAPLE and variable ordering $[z, x, y]$ (that is, $z > x > y$).

Notes:

Source: [BH91]

5.2 Intersection B

$$(\exists z) \left[x^2 - \frac{1}{2}y^2 - \frac{1}{2}z^2 = 0 \right] \wedge [xz + zy - 2x = 0] \wedge [z^2 - y = 0]. \quad (26)$$

Free Variables: x, y .

Quantified Variables: z .

Suggested variable order: $z > x > y$

Minimal achieved number of cells: 2795 – with MAPLE and variable ordering $[z, x, y]$ (that is, $z > x > y$).

Notes:

Source: [BH91]

5.3 Random A

$$(\exists z)(\forall y)(\exists x) \left[4x^2 + xy^2 - z + \frac{1}{4} = 0 \right] \wedge \\ [2x + y^2z + \frac{1}{2} = 0] \wedge [x^2z - \frac{1}{2}x - y^2 = 0]. \quad (27)$$

Free Variables:

Quantified Variables: x, y, z .

Suggested variable order: $z > y > x$

Minimal achieved number of cells: 1267 – with MAPLE and variable ordering $[z, y, x]$ (that is, $z > y > x$).

Notes:

Source: [BH91]

5.4 Random B

$$(\exists x)(\forall y)(\exists z) \left[4x^2 + xy^2 - z + \frac{1}{4} = 0 \right] \wedge \\ [2x + y^2z + \frac{1}{2} = 0] \wedge [x^2z - \frac{1}{2}x - y^2 = 0]. \quad (28)$$

Free Variables:
 Quantified Variables: x, y, z .
 Suggested variable order: $x > y > z$
 Minimal achieved number of cells: 1267 – with MAPLE and variable ordering
 $[z, y, x]$ (that is, $z > y > x$).
 Notes:
 Source: [BH91]

5.5 Ellipse A

$$\begin{aligned}
 (\exists y)(\exists x) & \left[[x^2 + y^2 - 1 = 0] \wedge [b^2(x - c)^2 + a^2y^2 - a^2b^2 = 0] \right. \\
 & \left. \wedge [a > 0] \wedge [a < 1] \wedge [b > 0] \wedge [b < 1] \wedge [c \geq 0] \wedge [c < 1] \right]. \quad (29)
 \end{aligned}$$

Free Variables: a, b, c .
 Quantified Variables: x, y .
 Suggested variable order: $y > x > c > b > a$
 Minimal achieved number of cells: – with MAPLE and variable ordering $[, ,]$
 (that is, $>>$). Note that for this number only the first two equations were used
 to generate the CAD, the linear inequalities were omitted.
 Notes: Inspired by Kahan’s problem. Instead of having the ellipse contained
 in the circle, this looks for an intersection.
 Source: [BH91]

5.6 Ellipse B

$$\begin{aligned}
 (\exists x)(\exists y) & \left[[x^2 + y^2 - 1 = 0] \wedge [b^2(x - c)^2 + a^2y^2 - a^2b^2 = 0] \right. \\
 & \left. \wedge [a > 0] \wedge [a < 1] \wedge [b > 0] \wedge [b < 1] \wedge [c \geq 0] \wedge [c < 1] \right]. \quad (30)
 \end{aligned}$$

Free Variables: a, b, c .
 Quantified Variables: x, y .
 Suggested variable order: $x > y > c > b > a$
 Minimal achieved number of cells: – with MAPLE and variable ordering $[, ,]$
 (that is, $>>$).
 Notes: Inspired by Kahan’s problem. Instead of having the ellipse contained
 in the circle, this looks for an intersection.
 Source: [BH91]

5.7 Solotareff A

$$\begin{aligned}
 (\exists y)(\exists x) & \left[[3x^2 - 2x - a = 0] \wedge [x^3 - x^2 - ax - 2b + a - 2 = 0] \right. \\
 & \wedge [3y^2 - 2y - a = 0] \wedge [y^3 - y^2 - ay - a + 2 = 0] \wedge [1 \leq 4a] \wedge [4a \leq 7] \\
 & \left. \wedge [-3 \leq 4b] \wedge [4b \leq 3] \wedge [-1 \leq x] \wedge [x \leq 0] \wedge [0 \leq y] \wedge [y \leq 1] \right]. \quad (31)
 \end{aligned}$$

Free Variables: a, b .

Quantified Variables: x, y .

Suggested variable order: $y > x > b > a$

Minimal achieved number of cells: – with MAPLE and variable ordering $[, ,]$ (that is, $>>>$). Note that for this number only the first four equations were used to generate the CAD, the linear inequalities were omitted.

Notes:

Source: [BH91]

5.8 Solotareff B

$$\begin{aligned} & (\exists y)(\exists x) \left[[3x^2 - 2x - a = 0] \wedge [x^3 - x^2 - ax - 2b + a - 2 = 0] \right. \\ & \wedge [3y^2 - 2y - a = 0] \wedge [y^3 - y^2 - ay - a + 2 = 0] \wedge [1 \leq 4a] \wedge [4a \leq 7] \\ & \left. \wedge [-3 \leq 4b] \wedge [4b \leq 3] \wedge [-1 \leq x] \wedge [x \leq 0] \wedge [0 \leq y] \wedge [y \leq 1] \right]. \quad (32) \end{aligned}$$

Free Variables: a, b .

Quantified Variables: x, y .

Suggested variable order: $y > x > a > b$

Minimal achieved number of cells: – with MAPLE and variable ordering $[, ,]$ (that is, $>>>$). Note that for this number only the first four equations were used to generate the CAD, the linear inequalities were omitted.

Notes:

Source: [BH91]

5.9 Collision A

$$\begin{aligned} & (\exists y)(\exists x)(\exists t) \left[\left[\frac{1}{4}(x - t)^2 - (y - 10)^2 - 1 = 0 \right] \right. \\ & \left. \wedge \left[\frac{1}{4}(x - at)^2 + (y - at)^2 - 1 = 0 \right] \wedge [t > 0] \wedge [a > 0] \right]. \quad (33) \end{aligned}$$

Free Variables: a .

Quantified Variables: t, x, y .

Suggested variable order: $y > x > t > a$

Minimal achieved number of cells: – with MAPLE and variable ordering $[, ,]$ (that is, $>>>$).

Notes: In this problem t stands for time and the problem describes two ellipses with semi-axes 2 and 1. One is centered at $(0, 10)$ moving with horizontal velocity 1. The other is centered at the origin and moving with velocity (a, a) . The problem decides if the ellipses collide.

Source: [BH91]

5.10 Collision B

$$\begin{aligned} & (\exists t)(\exists y)(\exists x) \left[\left[\frac{1}{4}(x - t)^2 - (y - 10)^2 - 1 = 0 \right] \right. \\ & \left. \wedge \left[\frac{1}{4}(x - at)^2 + (y - at)^2 - 1 = 0 \right] \wedge [t > 0] \wedge [a > 0] \right]. \quad (34) \end{aligned}$$

Free Variables: a .

Quantified Variables: t, x, y .

Suggested variable order: $t > x > y > a$

Minimal achieved number of cells: – with MAPLE and variable ordering $[, ,]$
(that is, $>>$).

Notes: In this problem t stands for time and the problem describes two ellipses with semi-axes 2 and 1. One is centered at $(0, 10)$ moving with horizontal velocity 1. The other is centered at the origin and moving with velocity (a, a) . The problem decides if the ellipses collide.

Source: [BH91]

6 Other Examples

6.1 Off-Center Ellipse

$$[a \neq 0] \wedge (\forall x)(\forall y)[16a^2y^2 - 8a^2y + 4x^2 - 4x - 3a^2 + 1 = 0] \\ \longrightarrow [y^2 + x^2 - 1 \leq 0] \quad (35)$$

Free Variables: a .

Quantified Variables: x, y .

Suggested variable order:

Best achieved number of cells: 1097 (MAPLE with suggested ordering).

Notes: Deciding if an off-center ellipse with center $(\frac{1}{2}, \frac{1}{4})$, semi-major axis a and semi-minor axis $\frac{1}{2}$ lies within the unit circle centered at the origin.

Source: [AM88]

6.2 Concentric Circles

$$x^2 + y^2 - 9 = 0 \quad (36)$$

$$x^2 + y^2 - 1 = 0 \quad (37)$$

Free Variables: x, y .

Quantified Variables:

Suggested variable order: $y > x$.

Best achieved number of cells: 41 (MAPLE with suggested ordering).

Notes:

Source: [Dav11]

6.3 Non-Concentric Circles

$$x^2 + y^2 - 9 = 0 \quad (38)$$

$$x^2 + (y - 1)^2 - 1 = 0 \quad (39)$$

Free Variables: x, y .

Quantified Variables:

Suggested variable order: $y > x$.

Best achieved number of cells: 41 (MAPLE with suggested ordering).

Notes: Note that an extra spurious point is added compared to the concentric case - corresponding to the “complex intersection” of the circles.

Source: [Dav11]

6.4 Edges Square Product

$$(\exists x_1)(\exists x_2)(\exists y_2) \left[[x = x_1x_2 - y_2] \wedge [y = x_1y_2 + x + 2] \right. \\ \wedge [0 \leq x_1] \wedge [x_1 \leq 2] \wedge [2 \leq x_2] \wedge [x_2 \leq 4] \wedge [-1 \leq y_2] \\ \left. \wedge [y_2 \leq 1] \wedge [-1 \leq x] \wedge [x \leq 9] \wedge [-6 \leq y] \wedge [y \leq 6] \right] \quad (40)$$

Free Variables: x, y
 Quantified Variables: x_1, x_2, y_2
 Suggested variable order:
 Best achieved number of cells:
 Notes: Originally stated by Collins. Solution given in Figure 1.
 Source: [BG06]

6.5 Simplified Edges Square Product

$$\begin{aligned}
 (\exists x_1) \Big[& [-x_1 \leq 0] \wedge [x_1 \leq 2] \wedge [0 \leq 1 + x] \wedge [x \leq 9] \wedge \\
 & [0 \leq y + 6] \wedge [y \leq 6] \wedge [0 \leq -(x_1^2 + 1)(-y - x_1x + 2x_1^2 + 2)] \wedge \\
 & [(-x + x_1y)(x_1^2 + 1) \leq (x_1^2 + 1)^2] \wedge [x_1^2 + 1 \neq 0] \wedge \\
 & [0 \leq (x_1^2 + 1)(x_1^2 + 1 - x + x_1y)] \wedge [(x_1^2 + 1)(y + x_1x) \leq 4(x_1^2 + 1)^2] \Big] \quad (41)
 \end{aligned}$$

Free Variables: x, y
 Quantified Variables: x_1
 Suggested variable order:
 Best achieved number of cells:
 Notes: Simplified version of the Edges Square Product given in [BG06] using $x_2 = y - x_1y_2$ and $y_2 = (-x + x_1y)/(x_1^2 + 1)$. Solution given in Figure 1. A partial CAD in QEPCAD produces 1049 cells.
 Source: [BG06]

6.6 Putnum Example

$$\begin{aligned}
 (\exists x_1)(\exists y_1)(\exists x_2)(\exists y_2) \Big[& x_1^2 + y_1^2 - 1 = 0 \wedge (x_2 - 10)^2 + y_2^2 - 9 = 0 \\
 & \wedge x = \frac{x_1 + x_2}{2} \wedge y = \frac{y_1 + y_2}{2} \Big] \quad (42)
 \end{aligned}$$

Free Variables: x, y .
 Quantified Variables: x_1, y_1, x_2, y_2
 Suggested variable order:
 Best achieved number of cells: 1521 (MAPLE with ordering $[x, y, a, b, c, d]$).
 Notes: Problem 2 from the 57th Putnam competition. What points are halfway between the points on the unit circle centered on the origin and a circle with radius 3 centered at (10, 0). Solution shown in blue in Figure 3.
 Source: [BG06]

6.7 Simplified Putnum

$$\begin{aligned}
 (\exists x_1)(\exists y_2) \Big[& (x_1^2 + 4y_2^2 - 4yy_2 + y_2^2 - 1 = 0) \\
 & \wedge (4x^2 - 4xx_1 - 40x + x_1^2 + 20x_1 + 91 + y_2^2 = 0) \Big] \quad (43)
 \end{aligned}$$

Free Variables: x, y .

Quantified Variables: x_1, y_2
Suggested variable order:
Best achieved number of cells: 21 (MAPLE with ordering $[\mathbf{x}, \mathbf{y}, \mathbf{a}, \mathbf{d}]$).
Notes: The Putnum example following simplifications $x_2 := 2x - x_1$ and $y_1 := 2y - y_2$. Solution shown in blue in Figure 3.
Source: [BG06]

6.8 YangXia

$$\begin{aligned}
(\exists s)(\exists b)(\exists c) \Big[& (a^2h^2 - 4s(s-a)(s-b)(s-c) = 0) \wedge (2Rh - bc = 0) \wedge \\
& (2s - a - b - c = 0) \wedge (b > 0) \wedge (c > 0) \wedge (R > 0) \wedge (h > 0) \wedge \\
& (a + b - c > 0) \wedge (b + c - a > 0) \wedge (c + a - b > 0) \Big]. \quad (44)
\end{aligned}$$

Free Variables: a, h, R .
Quantified Variables: s, b, c .
Suggested variable order:
Best achieved number of cells:
Notes:
Source: [BG06]

6.9 Simplified YangXia

$$\begin{aligned}
(\exists b) \Big[& (-\frac{1}{2}b \neq 0) \wedge (0 < R) \wedge (0 < b) \wedge (0 < h) \wedge \\
& (\frac{1}{16}a^2h^2b^4 - \frac{1}{32}a^2b^6 - \frac{1}{8}a^2R^2h^2b^2 - \frac{1}{8}R^2h^2b^4 + \frac{1}{64}b^8 + \frac{1}{64}a^4b^4 + \frac{1}{4}R^4h^4 = 0) \wedge \\
& (0 < -\frac{1}{4}(-ab - b^2 + 2Rh)b) \wedge (0 < \frac{1}{2}Rhb) \wedge \\
& (0 < \frac{1}{4}(2Rh + ab - b^2)b) \wedge (0 < \frac{1}{4}(b^2 + 2Rh - ab)b) \Big]. \quad (45)
\end{aligned}$$

Free Variables: a, h, R
Quantified Variables: b .
Suggested variable order: $b > a > h > R$.
Best achieved number of cells: 1067 (MAPLE with ordering $[\mathbf{a}, \mathbf{h}, \mathbf{R}, \mathbf{b}]$).
Notes: Simplified YangXia using $s := \frac{1}{2}(a + b + c)$ and $c := \frac{2Rh}{b}$.
Source: [BG06]

6.10 SEIT Model

$$\begin{aligned}
(\exists s)(\exists F)(\exists J)(\exists T) \Big[& [d - ds - b_1Js = 0] \wedge [vF - (d + r_2)J = 0] \wedge \\
& [b_1J + b_2JT - (d + v + r_1)F + (1 - q)r_2J = 0] \wedge [-dT + r_1F + qr_2J - b^2TJ = 0] \wedge \\
& [F > 0] \wedge [J > 0] \wedge [T > 0] \wedge [s > 0] \wedge [b_1 > 0] \wedge [d > 0] \wedge \\
& [v > 0] \wedge [r_1 > 0] \wedge [r_2 > 0] \wedge [q > 0] \wedge [b_1 > b_2] \Big]. \quad (46)
\end{aligned}$$

Free Variables: $b_1, b_2, d, q, r_1, r_2, v$.

Quantified Variables: s, F, J, T .

Suggested variable order:

Best achieved number of cells:

Notes: SEIT Model is used in epidemic modeling. This problem asks for the existence of an endemic equilibrium.

Source: [BG06]

6.11 Simplified SEIT Model

$$\begin{aligned}
(\exists J) \left[[0 < d] \wedge [0 < r_1] \wedge [0 < r_2] \wedge [0 < q] \wedge [b_2 < b_1] \wedge [0 < v] \wedge \right. \\
[0 < J] \wedge [0 < b_1] \wedge [0 < b_2] \wedge [d + Jb_1 \neq 0] \wedge [-v \neq 0] \wedge \\
[0 < (d + r_2)Jv] \wedge [vb_2 \neq 0] \wedge [0 < d(d + Jb_1)] \wedge \\
[0 < (d + Jb_1)b_2v(-d vb_1 + d^2 v + d^2 r_2 + dvr_2q + d^3 + d^2 r_1 + Jb_1vr_2q + \\
dr_2r_1 + Jb_1dv + Jb_1dr_2 + Jb_1r_2r_1 + Jb_1d^2 + Jb_1dr_1)] \wedge \\
[-(d + Jb_1)b_2v^3d(-d vb_1 - Jb_1vb_2 + d^2 v + d^2 r_1 + dvr_2q + d^3 + \\
b_2Jd^2 + d^2 r_2 + dr_2r_1 + b_2Jdv + b_2Jdr_2 + Jb_1dv + Jb_1dr_1 + Jb_1vr_2q + \\
Jb_1d^2 + J^2b_1db_2 + Jb_1dr_2 + Jb_1r_2r_1 + J^2b_1b_2v + J^2b_1r_2b_2) = 0] \left. \right]. \quad (47)
\end{aligned}$$

Free Variables: $b_1, b_2, d, q, r_1, r_2, v$.

Quantified Variables: J .

Suggested variable order: $J > r_1 > q > r_2 > b_2 > v > d > b_1$

Best achieved number of cells:

Notes: Simplified using $F := (d + r_2)J/v$, factorization and substitution of $J := 0$, $T := (-vb_1s + dr_1 + vr_2q + d^2 + dv + dr_2 + r_2r_1)/(vb_2)$ and $v := 0$, as well as the substitution $s := d/(d + Jb_1)$ and cutting of all contradicting subformulas.

Source: [BG06]

6.12 Cyclic—3

$$(\exists b)(\exists a) \left[[a + b + c = 0] \wedge [ab + bc + ca = 0] \wedge [abc - 1 = 0] \right]. \quad (48)$$

Free Variables: a .

Quantified Variables: b, c .

Suggested variable order: $a > b > c$.

Best achieved number of cells: 381 (MAPLE with suggested ordering).

Notes:

Source:

6.13 Cyclic—4

$$\begin{aligned}
(\exists c)(\exists b)(\exists a) \left[[a + b + c + d = 0] \wedge [ab + bc + cd + da = 0] \wedge \right. \\
\left. [abc + bcd + cda + dab = 0] \wedge [abcd - 1 = 0] \right]. \quad (49)
\end{aligned}$$

Free Variables: a .
 Quantified Variables: b, c, d .
 Suggested variable order: $a > b > c > d$.
 Best achieved number of cells:
 Notes:
 Source:

6.14 Joukowski Transformation

This example has been moved to Section 7 for further discussion.

7 Joukowski Transformation

Proving, using cylindrical algebraic decomposition, that the Joukowski transformation is injective on certain subsets of the complex plane has proven a formidable task. Various formulations of this problem are listed in this section.

7.1 Original Formulation

$$\begin{aligned}
 (\forall a)(\forall b)(\forall c)(\forall d) & \left[[a(c^2 + d^2)(a^2 + b^2 + 1) - c(a^2 + b^2)(c^2 + d^2 + 1) = 0] \right. \\
 & \wedge [b(c^2 + d^2)(a^2 + b^2 - 1) - d(a^2 + b^2)(c^2 + d^2 - 1) = 0] \wedge [bd > 0] \\
 & \left. \wedge [c^2 + d^2 - 1 > 0] \right] \implies [[a = c] \wedge [b = d]]. \quad (50)
 \end{aligned}$$

Free Variables:
 Quantified Variables: a, b, c, d .
 Suggested variable order: $a > b > c > d$.
 Best achieved number of cells:
 Notes: Showing the truth of this statement is equivalent to proving that the Joukowski transformation, $\zeta \mapsto \frac{1}{2} \left(1 + \frac{1}{\zeta} \right)$, is injective on $D = \{z \mid |z| > 1\}$.
 Source:

7.2 Separate Clauses

$$\begin{aligned}
 (\exists a)(\exists b)(\exists c)(\exists d) & \left[\right. \\
 b^2cd^2 + a^2cd^2 - ab^2d^2 - a^3d^2 - ad^2 + b^2c^3 + a^2c^3 - ab^2c^2 - a^3c^2 - ac^2 + b^2c + a^2c & = 0 \\
 \wedge b^2d^3 + a^2d^3 - b^3d^2 - a^2bd^2 + bd^2 + b^2c^2d + a^2c^2d - b^2d - a^2d - b^3c^2 - a^2bc^2 + bc^2 & = 0 \\
 & \left. \wedge db > 0 \wedge d^2 + c^2 - 1 > 0 \wedge c - a \neq 0 \right] \quad (51)
 \end{aligned}$$

Free Variables:
 Quantified Variables: a, b, c, d .
 Suggested variable order: $a > b > c > d$.
 Best achieved number of cells:

Notes: This formulation is achieved by negating the original formulation, and splitting into two clauses (dependant on whether the final term is $a \neq c$ or $b \neq d$). Therefore this should be shown to be false for the original Joukowski problem to be proven true.

7.3 Joukowski Upper Half Plane

$$\begin{aligned}
& (\forall a)(\forall b)(\forall c)(\forall d) \left[[a(c^2 + d^2)(a^2 + b^2 + 1) - c(a^2 + b^2)(c^2 + d^2 + 1) = 0] \right. \\
& \quad \wedge [b(c^2 + d^2)(a^2 + b^2 - 1) - d(a^2 + b^2)(c^2 + d^2 - 1) = 0] \wedge [b > 0] \\
& \quad \left. \wedge [d > 0] \right] \implies [[a = c] \wedge [b = d]]. \quad (52)
\end{aligned}$$

Free Variables:

Quantified Variables: a, b, c, d .

Suggested variable order: $a > b > c > d$.

Best achieved number of cells:

Notes: Showing the truth of this statement is equivalent to proving that the Joukowski transformation, $\zeta \mapsto \frac{1}{2} \left(1 + \frac{1}{\zeta} \right)$, is injective on $\mathbf{H}^+ = \{z \mid \Re(z) > 0\}$.

Source:

8 TTICAD Examples

The following examples were used in the forthcoming paper ‘‘Cylindrical Algebraic Decompositions for Boolean Combinations’’ (authors: Bradford, Davenport, England, McCallum and Wilson) which is being submitted to ISSAC 2013. As in Section 5, two versions of each problem are given with different variable orderings: an A and B version.

8.1 Intersection † A

$$[[xz + zy - 2x = 0] \vee [[z^2 - y = 0] \wedge [2x^2 - y^2 - z^2 < 0]]] \quad (53)$$

Free Variables: z, y, x

Quantified Variables:

Suggested Variable ordering: $z > y > x$

Best achieved number of cells:

Notes:

Source: Adapted from [BH91]

8.2 Intersection † B

$$[[xz + zy - 2x = 0] \vee [[z^2 - y = 0] \wedge [2x^2 - y^2 - z^2 < 0]]] \quad (54)$$

Free Variables: z, y, x

Quantified Variables:

Suggested Variable ordering: $z > x > y$

Best achieved number of cells:

Notes:

Source: Adapted from [BH91]

8.3 Random † A

$$[[16x^2 + 4xy^2 - 4z + 1 = 0] \vee [[4x + 2y^2z + 1 = 0] \wedge [2x^2z - x - 2y^2 < 0]]] \quad (55)$$

Free Variables: z, y, x

Quantified Variables:

Suggested Variable ordering: $z > y > x$

Best achieved number of cells:

Notes:

Source: Adapted from [BH91]

8.4 Random † B

$$[[16x^2 + 4xy^2 - 4z + 1 = 0] \vee [[4x + 2y^2z + 1 = 0] \wedge [2x^2z - x - 2y^2 < 0]]] \quad (56)$$

Free Variables: z, x, y

Quantified Variables:

Suggested Variable ordering: $z > x > y$

Best achieved number of cells:

Notes:

Source: Adapted from [BH91]

8.5 Ellipse † A

$$[[x^2 + y^2 - 1 = 0] \vee [[b^2x^2 - 2b^2xc + b^2c^2 + a^2y^2 - a^2b^2 = 0] \wedge [a > 0] \wedge [a - 1 < 0] \wedge [b > 0] \wedge [b - 1 < 0] \wedge [c > 0] \wedge [c - 1 < 0]]] \quad (57)$$

Free Variables: y, x, c, b, a

Quantified Variables:

Suggested Variable ordering: $y > x > c > b > a$

Best achieved number of cells:

Notes:

Source: Adapted from [BH91]

8.6 Ellipse † B

$$[[x^2 + y^2 - 1 = 0] \vee [[b^2x^2 - 2b^2xc + b^2c^2 + a^2y^2 - a^2b^2 = 0] \wedge [a > 0] \wedge [a - 1 < 0] \wedge [b > 0] \wedge [b - 1 < 0] \wedge [c > 0] \wedge [c - 1 < 0]]] \quad (58)$$

Free Variables: y, x, c, b, a

Quantified Variables:

Suggested Variable ordering: $x > y > c > b > a$

Best achieved number of cells:

Notes:

Source: Adapted from [BH91]

8.7 Solotareff † A

$$\begin{aligned} & [[[3x^2 - 2x - a = 0] \wedge [x^3 - x^2 - ax - 2b + a - 2 > 0] \wedge [4a - 1 > 0] \wedge [4a - 7 < 0] \wedge \\ & [x + 1 > 0] \wedge [x < 0]] \vee [[3y^2 - 2y - a = 0] \wedge [y^3 - y^2 - ay - a + 2 > 0] \wedge \\ & [4b + 3 > 0] \wedge [4b - 3 < 0] \wedge [y > 0] \wedge [y - 1 < 0]]] \quad (59) \end{aligned}$$

Free Variables: y, x, b, a

Quantified Variables:

Suggested Variable ordering: $y > x > b > a$

Best achieved number of cells:

Notes:

Source: Adapted from [BH91]

8.8 Solotareff † B

$$\begin{aligned} & [[[3x^2 - 2x - a = 0] \wedge [x^3 - x^2 - ax - 2b + a - 2 > 0] \wedge [4a - 1 > 0] \wedge [4a - 7 < 0] \wedge \\ & [x + 1 > 0] \wedge [x < 0]] \vee [[3y^2 - 2y - a = 0] \wedge [y^3 - y^2 - ay - a + 2 > 0] \wedge \\ & [4b + 3 > 0] \wedge [4b - 3 < 0] \wedge [y > 0] \wedge [y - 1 < 0]]] \quad (60) \end{aligned}$$

Free Variables: y, x, b, a

Quantified Variables:

Suggested Variable ordering: $y > x > a > b$

Best achieved number of cells:

Notes:

Source: Adapted from [BH91]

8.9 Collision † A

$$\begin{aligned} & [[[x^2 - 2xt + t^2 + 4y^2 - 80y + 396 = 0] \wedge [t > 0]] \vee \\ & [[x^2 - 2xat + 5a^2t^2 + 4y^2 - 8yat - 4 = 0] \wedge [a > 0]]] \quad (61) \end{aligned}$$

Free Variables: y, x, t, a

Quantified Variables:

Suggested Variable ordering: $y > x > t > a$

Best achieved number of cells:

Notes:

Source: Adapted from [BH91]

8.10 Collision † B

$$\begin{aligned} & [[[x^2 - 2xt + t^2 + 4y^2 - 80y + 396 = 0] \wedge [t > 0]] \vee \\ & [[x^2 - 2xat + 5a^2t^2 + 4y^2 - 8yat - 4 = 0] \wedge [a > 0]]] \quad (62) \end{aligned}$$

Free Variables: y, x, t, a

Quantified Variables:

Suggested Variable ordering: $t > x > y > a$

Best achieved number of cells:

Notes:

Source: Adapted from [BH91]

8.11 Kahan A

$$\begin{aligned} & [[[8y^3x + 8yx^3 + 20y^3 + 84yx^2 + 288yx + 324y = 0] \wedge \\ & [-225x^2 - 324x + 63y^2 - 4x^4 - 52x^3 + 12y^2x + 4y^4 < 0]] \vee [[2y = 0] \wedge [2x + 9 < 0]] \vee \\ & [[8y = 0] \wedge [8x^2 + 56x + 8y^2 + 96 < 0]] \vee [[y = 0] \wedge [x^2 + 7x + y^2 + 12 < 0]] \vee \\ & \quad [[8y^3x + 8yx^3 + 20y^3 + 84yx^2 + 288yx + 324y = 0] \wedge \\ & \quad [-4x^4 - 52x^3 - 252x^2 + 12y^2x - 540x + 36y^2 + 4y^4 - 432 \leq 0] \wedge \\ & \quad [4x^4 + 52x^3 + 225x^2 - 12y^2x + 324x - 63y^2 - 4y^4 < 0]] \vee \\ & \quad [[2y = 0] \wedge [-2x - 6 < 0] \wedge [2x \leq 0]] \vee [[8y = 0] \wedge \\ & \quad [-8x^2 - 56x - 8y^2 - 96 < 0] \wedge [2x^2 + 8x + 2y^2 \leq 0]] \end{aligned} \quad (63)$$

Free Variables: y, x

Quantified Variables:

Suggested Variable ordering: $y > x$

Best achieved number of cells:

Notes:

Source:

8.12 Kahan B

$$\begin{aligned} & [[[8y^3x + 8yx^3 + 20y^3 + 84yx^2 + 288yx + 324y = 0] \wedge \\ & [-225x^2 - 324x + 63y^2 - 4x^4 - 52x^3 + 12y^2x + 4y^4 < 0]] \vee [[2y = 0] \wedge [2x + 9 < 0]] \vee \\ & [[8y = 0] \wedge [8x^2 + 56x + 8y^2 + 96 < 0]] \vee [[y = 0] \wedge [x^2 + 7x + y^2 + 12 < 0]] \vee \\ & \quad [[8y^3x + 8yx^3 + 20y^3 + 84yx^2 + 288yx + 324y = 0] \wedge \\ & \quad [-4x^4 - 52x^3 - 252x^2 + 12y^2x - 540x + 36y^2 + 4y^4 - 432 \leq 0] \wedge \\ & \quad [4x^4 + 52x^3 + 225x^2 - 12y^2x + 324x - 63y^2 - 4y^4 < 0]] \vee \\ & \quad [[2y = 0] \wedge [-2x - 6 < 0] \wedge [2x \leq 0]] \vee [[8y = 0] \wedge \\ & \quad [-8x^2 - 56x - 8y^2 - 96 < 0] \wedge [2x^2 + 8x + 2y^2 \leq 0]] \end{aligned} \quad (64)$$

Free Variables: y, x

Quantified Variables:

Suggested Variable ordering: $x > y$

Best achieved number of cells:

Notes:

Source:

8.13 ArcSin A

$$\begin{aligned} & [[[-2xy = 0] \wedge [y^2 - x^2 + 1 < 0]] \vee [[16y^3x - 16yx^3 + 8yx = 0] \wedge \\ & [1 - 4x^2 + 4y^2 + 4x^4 - 24x^2y^2 + 4y^4 \leq 0]] \vee [[y = 0] \wedge [1 - x \leq 0]] \\ & \vee [[y = 0] \wedge [x + 1 \leq 0]]] \quad (65) \end{aligned}$$

Free Variables: y, x

Quantified Variables:

Suggested Variable ordering: $y > x$

Best achieved number of cells:

Notes:

Source:

8.14 ArcSin B

$$\begin{aligned} & [[[-2xy = 0] \wedge [y^2 - x^2 + 1 < 0]] \vee [[16y^3x - 16yx^3 + 8yx = 0] \wedge \\ & [1 - 4x^2 + 4y^2 + 4x^4 - 24x^2y^2 + 4y^4 \leq 0]] \vee [[y = 0] \wedge [1 - x \leq 0]] \\ & \vee [[y = 0] \wedge [x + 1 \leq 0]]] \quad (66) \end{aligned}$$

Free Variables: y, x

Quantified Variables:

Suggested Variable ordering: $x > y$

Best achieved number of cells:

Notes:

Source:

8.15 2D Example A

$$[[[x^2 + y^2 - 1 = 0] \wedge [4xy - 1 < 0]] \vee [[x^2 - 8x + 16 + y^2 - 2y = 0] \wedge [4xy - 4x - 17 < 0]]] \quad (67)$$

Free Variables: y, x

Quantified Variables:

Suggested Variable ordering: $y > x$

Best achieved number of cells:

Notes:

Source:

8.16 2D Example B

$$[[[x^2 + y^2 - 1 = 0] \wedge [4xy - 1 < 0]] \vee [[x^2 - 8x + 16 + y^2 - 2y = 0] \wedge [4xy - 4x - 17 < 0]]] \quad (68)$$

Free Variables: y, x

Quantified Variables:

Suggested Variable ordering: $x > y$

Best achieved number of cells:

Notes:

Source:

8.17 3D Example A

$$\begin{aligned} &[[[x^2 + y^2 + z^2 - 1 = 0] \wedge [4xyz - 1 < 0]] \vee [[x^2 - 8x + y^2 - 2y + z^2 - 4z + 20 = 0] \wedge \\ &[4yxz - 8yx - 4xz + 8x - 16yz + 32y + 16z - 33 < 0]]] \quad (69) \end{aligned}$$

Free Variables: z, y, x

Quantified Variables:

Suggested Variable ordering: $z > y > x$

Best achieved number of cells:

Notes:

Source:

8.18 3D Example B

$$\begin{aligned} &[[[x^2 + y^2 + z^2 - 1 = 0] \wedge [4xyz - 1 < 0]] \vee [[x^2 - 8x + y^2 - 2y + z^2 - 4z + 20 = 0] \wedge \\ &[4yxz - 8yx - 4xz + 8x - 16yz + 32y + 16z - 33 < 0]]] \quad (70) \end{aligned}$$

Free Variables: z, y, x

Quantified Variables:

Suggested Variable ordering: $z > x > y$

Best achieved number of cells:

Notes:

Source:

A Figures

The following are a list of figures to accompany the examples.

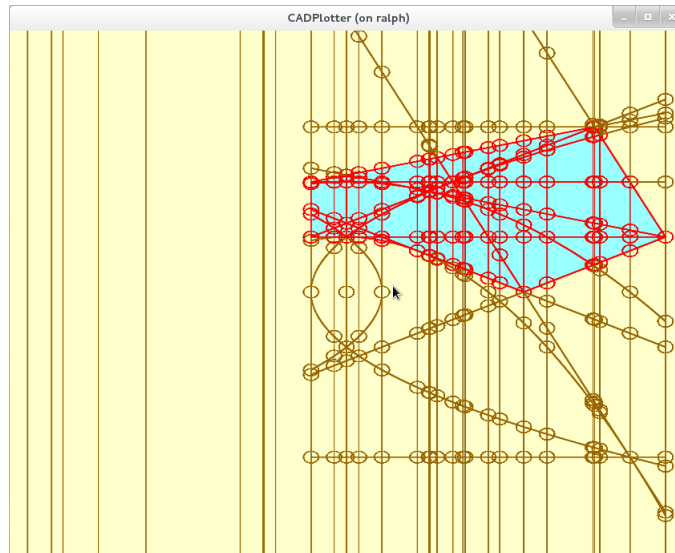

Figure 1: CAD produced for the Edges Square Product problem

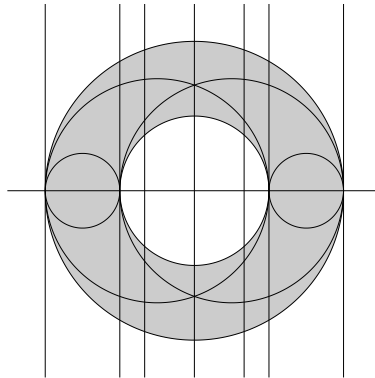

Figure 2: Partial CAD generated from the Simplified Putnum problem

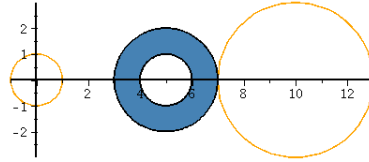

Figure 3: Solution set for the Putnum example, plotted with the original circles.

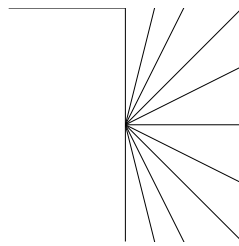

Figure 4: 2D-CAD produced for the simplified YangXia problem (R against h)

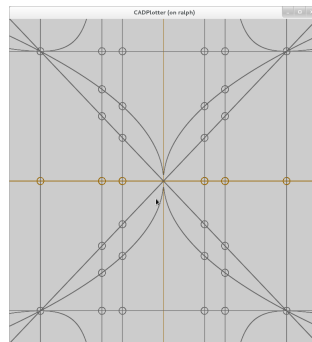

Figure 5: Projected 2D-CAD produced for the X-axis ellipse problem

References

- [Ach56] N. I. Achieser, *Solotareff's Problems and Related Problems*, Theory of Approximation, Frederick Ungar Publishing Co., New York, 1956, pp. 280–289.
- [AM88] Dennis S. Arnon and Maurice Mignotte, *On mechanical quantifier elimination for elementary algebra and geometry*, Journal of Symbolic Computation (1988), 237–259.
- [BG06] Christopher W Brown and Christian Gross, *Efficient Preprocessing Methods for Quantifier Elimination*, vol. 4194, Springer Berlin Heidelberg, Berlin, Heidelberg, 2006.
- [BH91] Bruno Buchberger and Hoon Hong, *Speeding-up Quantifier Elimination by Gröbner Bases*, RISC Report Series (1991), 1–21.
- [CH91] G Collins and H Hong, *Partial Cylindrical Algebraic Decomposition for quantifier elimination*, Journal of Symbolic Computation **12** (1991), no. 3, 299–328.
- [CMA82] George E Collins, Scott McCallum, and Dennis S. Arnon, *Cylindrical Algebraic Decomposition I: The Basic Algorithm*, Computer Science Technical Reports (1982).
- [CMXY09] Changbo Chen, Marc Moreno Maza, Bican Xia, and Lu Yang, *Computing Cylindrical Algebraic Decomposition via Triangular Decomposition*, ISSAC '09 (Seoul, Republic of Korea), ORCCA, University of Western Ontario, 2009, pp. 95–102.
- [Dav86] James H Davenport, *A "Piano Movers" Problem*, ACM SIGSAM Bulletin (1986).
- [Dav11] ———, *Exploring Cylindrical Algebraic Decomposition*, 1–3.
- [DH88] James H Davenport and Joos Heintz, *Real Quantifier Elimination is Doubly Exponential*, Journal of Symbolic Computation (1988).
- [DSS04] Andreas Dolzmann, Andreas Seidl, and Thomas Sturm, *Efficient Projection Orders for CAD*, the 2004 international symposium (New York, New York, USA), ACM Press, 2004, pp. 111–118.
- [Hon90] H Hong, *An improvement of the projection operator in cylindrical algebraic decomposition*, ... international symposium on Symbolic and algebraic ... (1990).
- [Laz88] D Lazard, *Quantifier elimination: Optimal solution for two classical examples*, Journal of Symbolic Computation (1988).
- [McC88] Scott McCallum, *An Improved Projection Operation for Cylindrical Algebraic Decomposition of Three-dimensional Space*, Journal of Symbolic Computation (1988), 141–161.
- [Phi11] Nalina Phisanbut, *Practical Simplification of Elementary Functions using Cylindrical Algebraic Decomposition*, Ph.D. thesis, University of Bath, 2011.